



Easy Oar

Newsletter of the Leichhardt Rowing Club
Issue 34
May, June, July, August 2012



A New Era for LRC

As we move into the regatta season for 2012/13, we welcome all our new members and also our many new Committee members. At the 126th Annual General Meeting held on Sunday 19 August, Tim Clare stepped down as LRC President, after 12 years in leadership roles at the Club (see Barry Moynahan's article) and we welcome Charles Bartlett into that role. Anne Parbury was elected as Captain and Charles Bezzina was elected as Property Master, both by secret ballot. Charles is already keen to share his knowledge with you, starting with an article on rigging in this issue of Easy Oar. We welcome new Vice Captain Zoe Thomas, returning Vice Captain Guy Elron and our new Junior Captain Dimitri Kastanias. Doreen Borg will be putting her administrative skills to use as Secretary, assisted by Jan McClelland as Assistant Secretary. We thank all those members who served on the Committee during the 2011/12 year.

AGM Report

The Annual Report, prepared for the AGM, is available on the website. It includes reports from the outgoing President, Captain, Treasurer, squad coaches, Pymble Ladies College and the Leichhardt Union of Old Rowers. In speaking to the Treasurer's report and financial statements, our auditor Bern Story, recognised that our finances have stabilised after a year of consolidation through minimising expenditure, while urging us to continue the effort to minimise day-to-day expenses and maximise income to use available funds to build our fleet for members' enjoyment.

Charles Bartlett has a great vision for the Club, which he shares with us in this issue of Easy Oar, and I'm sure everyone is looking forward to working with him and the new Committee towards a successful season, and a vibrant, positive and supportive Club atmosphere.

LEICHHARDT ROWING CLUB INC.

ABN 93 993 695 175

Glover Street Leichhardt NSW 2040 • PO Box 3 Leichhardt NSW 2040

OUR NEW COMMITTEE



President's Log — Charles Bartlett

Your new Committee, elected at the Annual General Meeting, is full of new faces to club administration, but we are all excited about making Leichhardt Rowing Club a fun place for all members. We are also keen to contribute to the future of the Club in a way that benefits all members both individually and collectively.

As your new President, I will be seeking to achieve these things by providing clear and consistent leadership without fear or favour. My expectation is that your new Committee will become more active than ever before, making it easy for members to quickly understand the direction the Club is heading. I aim to achieve this through transparent and consistent decision making and providing an opportunity for all members to be involved in implementing and playing a part in our future success, both on and off the water.

We have been a very successful club over the last decade, due in a large way to the size of our membership and the collective efforts of people who have invested their time in coaching others or playing a major role in the administration of the Club ahead of themselves or their own athletic endeavours. Our Club will always have such individuals come and go, but our continued success will be maintained by recruiting and developing new talent to strengthen our ranks and to ensure we grow rather than stand still.

I want all members to understand that each and everyone of us has a role to play in working towards a more vibrant and positive membership. I want every member to feel obliged to and positive about being actively involved in contributing in any way possible to the health of our Club. Not just their own on water activity but all activity around the shed. To this end I have been really encouraged by the response and congratulatory messages received on my appointment. I understand that many of our members are willing and want to contribute more. Well I accept your offers and I will be asking for help from many of you along the way as I seek your continued support.

The first way the membership can assist is to let me or any committee member know if there is something not quite right. And if at first you don't succeed try, try, and try again to get your message

understood. As a committee we can only address what we know is broken. Just like some of our boats and equipment. If it's broken don't leave it on the rack; do something about getting it fixed and if you can't do it yourself, tell someone who can. Your committee wants you to throw as many ideas at it as you have to offer and we want your help to implement.

On my priority list for the next few months will be finding ways to share the load of club administration and the organisation of events and activities that will help raise the funds we need to do all the things the membership expects, including purchasing new equipment. Our fleet of eights is old and tired and our small boats are in such demand we just need more of them. I am not a big supporter of spending good money on old boats (15 years plus) when for a little extra effort we could buy new equipment.

Raising funds through club events and donations is something your committee will be focusing on. So get ready for some fun times to share with your friends from inside and outside the club as we look for ways to increase our fund raising efforts. Your new committee has its first meeting on 3 September. I fully expect you will start to see some change about the club flowing from this meeting. The next few months will be very busy at Leichhardt as we move towards the start of another season. First off is the Corporate Regatta (thank you Steve Duff and all the crew coaches and catering team), Learn to Row (thank you Nitya and all the yet to be appointed coaches), Iron Cove Classic (thank you Deanna & Sandy who have taken control of this event), then numerous long distance regatta's including the trip to Melbourne for the Head of the Yarra. This year I look forward to several of our away events creating opportunity for all Leichhardt members and supporters to form stronger friendships and an understanding of the power of mutual support.

The season ahead can and will be full of fun and surprises. I am excited about guiding the Club's administration and look forward to continuing the good work of previous committee's, but with a touch of my own style and experience. I will have a keen eye for sound financial management, continued growth of the membership and improved rowing experiences for all. Let the fun begin!

Charles Bartlett, Club President

OUR NEW COMMITTEE

Introducing some of our new Committee Members



Charles Bezzina, Property Master

I started rowing with Leichhardt when I joined the Club's first learn to row program which was held when the new club

house had just been built. It was great fun learning to row, and I quickly became addicted, not just to rowing but also to the Club atmosphere, the comradeship and the enjoyment of working with boats.

Throughout my membership at LRC I have been actively involved in the maintenance of boats. I was a Committee member for a few years during which time I acted as assistant to the property master. My duties included repairs and adjustments to boats, ordering parts from suppliers and other general maintenance tasks. I'm looking forward to now taking on a wider role with more responsibility and strategic thinking, as well as hands-on involvement.

Kerry (like all the Property Masters before her) took on a huge level of responsibility for boat and building maintenance. During her time as Property

Master, she brought about some organisation towards ongoing maintenance with scheduled repair and maintenance days for not only the clubs fleet but also the club's facilities. I feel this is a great step forwards and I will be working closely with Kerry over the next year (or two) to consolidate on the work she has set in train.

While some of the scheduled maintenance is now being performed by contractors, there is still much that can and should be done by us, the club members. Please feel free to ask me questions about boat or property maintenance. I'm always happy to advise/assist where anyone is keen to learn, and I definitely won't say no to a good cup of coffee and a chat.

I am looking forward to working with all members at LRC to see that the facilities at LRC are kept in good working order for all members to enjoy. In addition to ongoing maintenance by all club members, I'm also looking for volunteers to fill the positions of assistants to the property master (juniors are welcome!) While the monetary remuneration may be non-existent, the fulfilment from a job well done truly makes up for it.

Charles Bezzina

2012-13 LRC COMMITTEE

Patron	Lionel Robberds
President	Charles Bartlett
Vice-Presidents	Bob Stone, Len McPherson, Tony Potter, Vic Williamson, Steve Roll, Bill Monaghan, Rodney Moynahan, Barry Moynahan, Michael Bath
Captain	Anne Parbury
Treasurer	Onno van Ewyk
Secretary	Doreen Borg
Property Master	Charles Bezzina
Vice-Captains	Guy Elron Dimitri Kastanias (Junior)
Assistant Treasurer	Sandra Rourke
Assistant Secretary	Jan McClelland
Regatta Secretary	Rebecca Storen
Committee Members	Steven Duff Dean Patterson David Hogan

Dimitri Kastanias, Junior Vice Captain

As Junior Vice Captain newly elected, I look forward to working with the LRC committee on behalf of my junior cohort. They are a gifted and bright group of young people and I feel it's important they maximise both their rowing potential and involvement in the club. I would like to see Leichhardt's proud history of junior participation in rowing continue and will endeavour towards this end.



Dimitri Kastanias

CLUB CHAT

President Tim Clare Steps Down

Our new President Charles Bartlett, elected on Sunday, 19th August, suggested I summarise Tim's contribution as Leichhardt Club's 24th President in its 125-year history.

Whilst due recognition must be given to strong executive and committee support, it is the President who is elected to preside over the organisation, develop and review policy, and where there is conflict, encourage a line of action based on precedence, wisdom and at times expediency.

The Club's first 120 years realised eight State Premierships, the last in 1989. Since 2006 and with Tim as President, the Club won a further four State Premierships - a remarkable achievement.

Tim's relationship with Leichhardt began whilst still a Pymble Ladies College parent with two rowing daughters. As with another Pymble stalwart Wade Hewett, Tim's supportive and hands-on approach, including active competitive Masters involvement, led to his election as Vice Captain in 2002, and subsequent appointment as Club Captain.

In his role as Club Captain, Tim's very successful business background, leadership qualities, a magnificent new clubhouse and the introduction of community "Learn to Row" programs, resulted in a substantial increase in membership. Income streams from an enhanced "Corporate Rowing" program had led to the appointment of a paid coach, and targets for competition across the broad range of new and existing programs. Indeed Tim's innovative approach has produced a most successful and financially secure community based rowing organisation.

Tim Clare's Presidency was always focussed on "vision" and like many visionaries, he leads from the front – sometimes so far in front that the voices of a few may have occasionally gone unheard. Even those would applaud the outcomes.

Tim had a wonderful working relationship with the late Peter Trives, and together with an enthusiastic club executive presented a forceful and united management team at Leichhardt.

I'm sure that a former President of the NSW Rowing Association would recall my suggestion that Tim should be invited to fill a vacant Director's position

on the Board—a position he held for eight years. His subsequent appointment as Chair of the Regatta Commission resulted in changes to the format of Association Regattas, a change of the classifications of rowers and the current "crew score system".

Tim's consultative approach in Association matters saw, although briefly, the introduction of the "Universal Sculls" and "Super Eights" – all innovations directed towards increasing the popularity of the sport for the young and encouraging the reappearance of many masters to social rowing and club competition.

As a Life Member of Leichhardt he has served the criteria for such an honour well, - twelve years of active executive management and a personal desire to continue competitively in Masters Rowing.

Charles, as our new President, has a tough act to follow, but like Tim, will rely on a great Club Captain in Anne, in the day to day operation of the Club, and the friendship and support of a strong executive, taking Leichhardt even further on its fabulous journey.

On behalf of the membership - thanks Tim for a job very well done.



**Barry Moynahan OAM
LRC Vice President**

At the AGM, Barry Moynahan proposed a vote of thanks to all LRC members who had served on the Club Committee for the 2011/12 season, and recognised the huge contribution that retiring President, Tim Clare has made to the Club over the years.

CLUB CHAT

LUOR LUNCH & BOAT CHRISTENING



The Leichhardt Union of Old Rowers meets twice a year. A report on its activities over the last year appears in the AGM Report. At the June meeting, LUOR christened a new Ted Hale Coxless Four Quad, donated to the Club by the Balcony Boyz. The boat was christened the "Lt Tom McGill A. I.E.F." in honour of a former First World War Club oarsman who was also a member of the original King's Cup eight oared crew in 1919. Tom's two surviving sons attended the Christening.



The LUOR June lunch also provided an excellent opportunity for a Club 125th Anniversary photograph of members and friends present (on the front cover).



CONGRATULATIONS!



Congratulations to rower and juniors coach Jen Zongor and her husband Paul Luchi on the birth of Anika Kate Luchi on 27 April.

CONGRATULATIONS & THANK YOU



Congratulations to Steve Roll who celebrated 60 years as a member of Leichhardt Rowing Club on 3 September. Thank you Steve for sticking with us and for your rowing and sculling achievements, advice, coaching and positive attitude to life and Club life. We're lucky to have you as a member.

REMINDER

Learn to Row started on Saturday 15 September with the information and registration session and continues on Saturdays and Sundays until 27 October, running two sessions each morning. We have had a huge response and will have many crews on the water. Please check the LRC website for details of times/dates, and email the Club Captain if you can help with coaching or tinny driving for Learn to Row. Also, please remember to be particularly aware of others when you're on the pontoon during Learn to Row sessions and lend a hand if required.

LRC Corporate Challenge 2012



The 2012 Corporate Challenge was a great success with 13 crews training at LRC and 15 crews taking part in the Corporate Regatta at SIRC on Sunday 9 September. Thank you to all our dedicated corporates coaches and assistant coaches who did a fantastic job, organisers Steve Duff and Deanna Fekete, and our volunteer coxswains and breakfast providers. Also a big thank you to all the Club members who helped at the Corporate regatta, including catering, starters, finishers, commentators, marshalls and everyone who helped with rigging, de-rigging and boat handling on the pontoons. It was a great team effort. More photos are on the Lrc website.



A Corporate Cox's Tale by Nancy Wahlquist

With parental duties abating, I had become fond of not having to get up before dawn for anyone other than myself, and had been wondering how I could wriggle out of my offer to be coxswain for a corporate 8 as my compulsory volunteer contribution to the club. However, when contacted and asked to be on the pontoon by 5.15 the next morning, I knew I was cornered – there was to be no escape. As I fumbled in the dark on that first Tuesday morning to plug my cox box in on the boat I cursed the lunacy of my chosen sport. However, once we were on the water with a sharp slip of moon in the sky with a satellite nearby attempting to emulate the Soviet flag, and later when the sun started to rise creating the most magnificent light show on the smooth water, I knew that the true lunatics were all those lazy bastards still tucked up in their boring old beds!

And then there were all those long oars.....oooooh..... they never fail to stir my Inner Viking.

That same first day, my father, carrier of my Viking genes, was admitted to hospital having suffered a minor stroke and heart attack. At 85 and with lungs full of asbestos from his time in the Navy, he is a living example of how a good diet, staying active mentally and physically, no smoking and a glass (or two, but never three) of red wine a day can really pay off. As kids, he built us sailing boats – Sabots and Herons – which we sailed from a clubhouse in Snails Bay, Balmain. I didn't take to the unpredictability of wind driven sports so well, (capsizing in the middle of the harbour when you are seven is SCARY), preferring instead to watch the rowers venturing out from Iron Cove, and longing to give it a go. But as the youngest of four, there was little chance of such an indulgence.

Rowing with my quad on Thursday and thinking of my Dad, who can no longer breathe deeply, I reached my head high at the catch and forced the chill air into the lower reaches of my lungs. I felt so sad that he would never do that again, and hoped that somehow I could breathe some in for him.

On the first Friday and the following Tuesday morning, some my corporate crew didn't turn up so we went out in the Michael Bath. What a bugger to steer, and with only four oars – it just didn't do it for me. But after a rallying cry from Deanna, we had a good roll up the following Tuesday and I had the pleasure of coxing the Steve Jacques – now that's steering, and enough oars to make it all worthwhile.

My Dad is out of hospital now, and living a much quieter life than he had been, cared for by my Mum. Rowing and coxing stir inside me a deep reminiscence of my ancestral heritage – and remind me of how much I love my Dad.

My crew from Transport Infrastructure NSW – Anna, Graeme, Steve, Peter, David, Leonie, Steve and Justine, are a happy lot and now they have completed their third week are really rowing together well under the guidance of Dave Hogan. I'm glad I volunteered to be coxswain for them.

LRC Corporate Challenge Regatta

The 2012 Corporate Regatta was held on a perfect day with calm water, lots of sunshine and some close racing. All our corporate crews rowed well and in great sporting spirit.

And the winners were:

Finance & Legal Cup – Long & Strong (HDY)

General Industry Cup - Apra Afloat (APRA)

Construction Industry Cup – CIP Motor Boaters (CIP)

LRC Championship Plate – Steady Sallies (PMP Direct)

LRC Championship Cup – Long & Strong (HDY)

Thank you to all our Corporate crews for taking part in the LRC Corporate Challenge:

Abigroup; APRA; CIP; Consep; Henry Davis York; Lumley; PMP Digital; and Transport for NSW. Thank you also to Club members who brought crews on board and rowed with them, or coxed them. We hope you've had fun!



CLUB CHAT

SECOND ANNUAL BOAT RALLY



At dawn on Sunday, 5 August, seven mixed 8+ crews from LRC and other clubs took to the waters of Iron Cove and beyond in search of answers..... Organiser Steve (Stavros) Duff reports on the second LRC Annual Boat Rally.

Thank goodness our Club Captain booked the weather in months ago. It was a glorious day for our second Boat Rally. Water like glass and the sun dazzling off the water. As dawn broke over Iron Cove, individuals mustered up the stairs at the LRC



clubhouse to register for the event. In all we ended up with enough participants to crew 7 eights. When you add in all the helpers we

probably had nearly 100 people present. This year we had members from several other clubs join us. Drummoyne and North Shore sent participants. Balmain sent a whole 8+.



Lionel Robberds was our honoured guest. He performed the draw for each boat; a random selection of males, females and coxes. Once chosen, each crew took their coloured bandanas and lane number to their boat ready for launching. With Stuart on the balcony watching (official time keeper) each crew was released with their sealed envelope of 45 questions. We had three tinnies following each group



of eights with a course map to assist if required, with captains Tim Lloyd, Steve Roll and Steve Sherry taking to the water with their



assistant crewmembers Zoe, Dan and Sue.



Slowly each eight gained confidence and speed to progress around the course collecting answers and coloured pennants. Some 90 to 120 minutes later after travelling to Sydney Womens Rowing Club and back, every crew returned with a burst to the finish line. Times were recorded, answers were marked and our officials Gerald and Stuart posted the results. Once again crew 5 won the day, coxed by Sam Wayland for the second year running (perhaps a good cox has value after all). The winning crew received their medals and a number 10 spanner along with



a crew photo to be cherished for the rest of their lives. The losing crew took their wooden spoons home to reflect on opportunities missed. The rest devoured the mountain of food supplied by Bec and cooked by Andy in no time. Next year we will have to monitor consumption!



Special mentions go to Balmain for bringing binoculars, Crew 1 for missing the first port of call (Drummoyne Shed) but collecting their pennant on the way back, Kerry's crew for having a dud cox box leaving the cox Sandra, to shout at her rabble for 2 hours, and to those coming from other clubs. Next year I hope to see over 10 eights from at least 4 clubs attending. In 5 years my target is 50 crews.

I hope you all met a few people you have never spoken to before. Say hi next time you see them. Well done to all.

Cheers Stavros

CLUB CHAT

GLOVER STREET UPGRADE between Mary St and LRC

Leichhardt Municipal Council is reconstructing and upgrading the parking arrangements in Glover Street.

Work will commence on or about 10 September 2012. It will be mostly on the eastern (Rozelle Hospital) side and take approximately 2 weeks to complete. Normal construction hours are from 7:00am to 3:00pm Monday to Friday.

Traffic, parking and access changes:

Barricades and signage will be installed around the worksite.

During construction parking on the western (Oval or toilet block) side will be maintained.

Parking on the eastern (Rozelle Hospital) side will be restricted.

Minor traffic delays may occur during construction times to allow heavy vehicles to enter and leave the site.

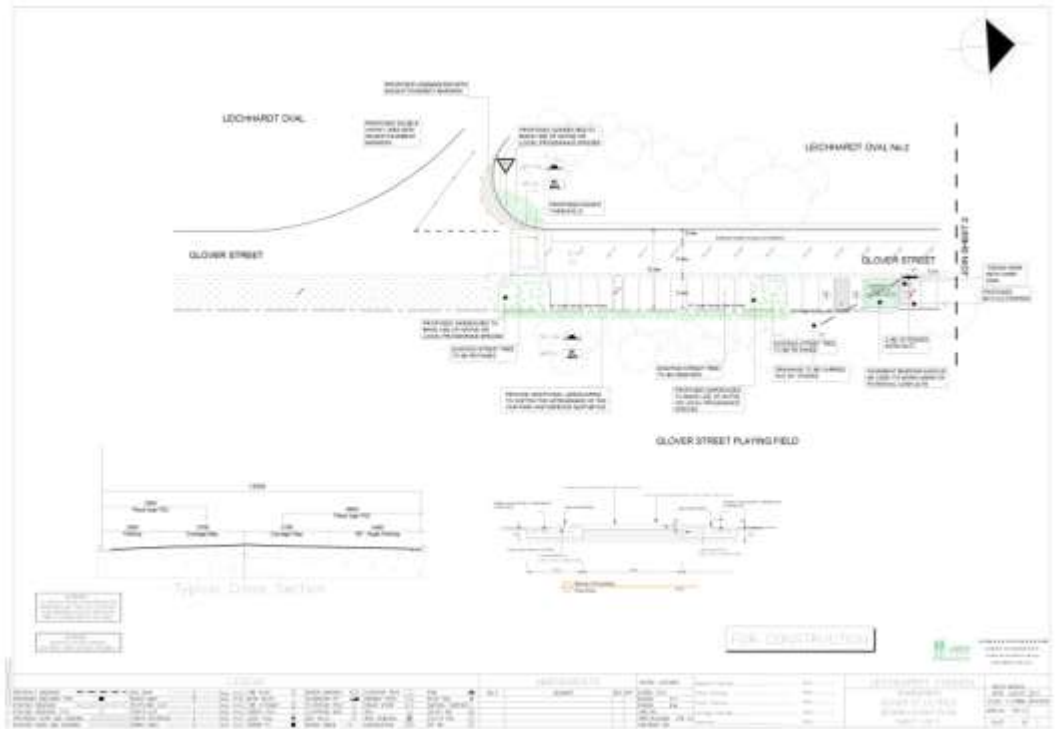

LRC Members are asked to:

Observe all directions given by Councils contractors

Stay clear of the works area

Do not park in the works areas at any time

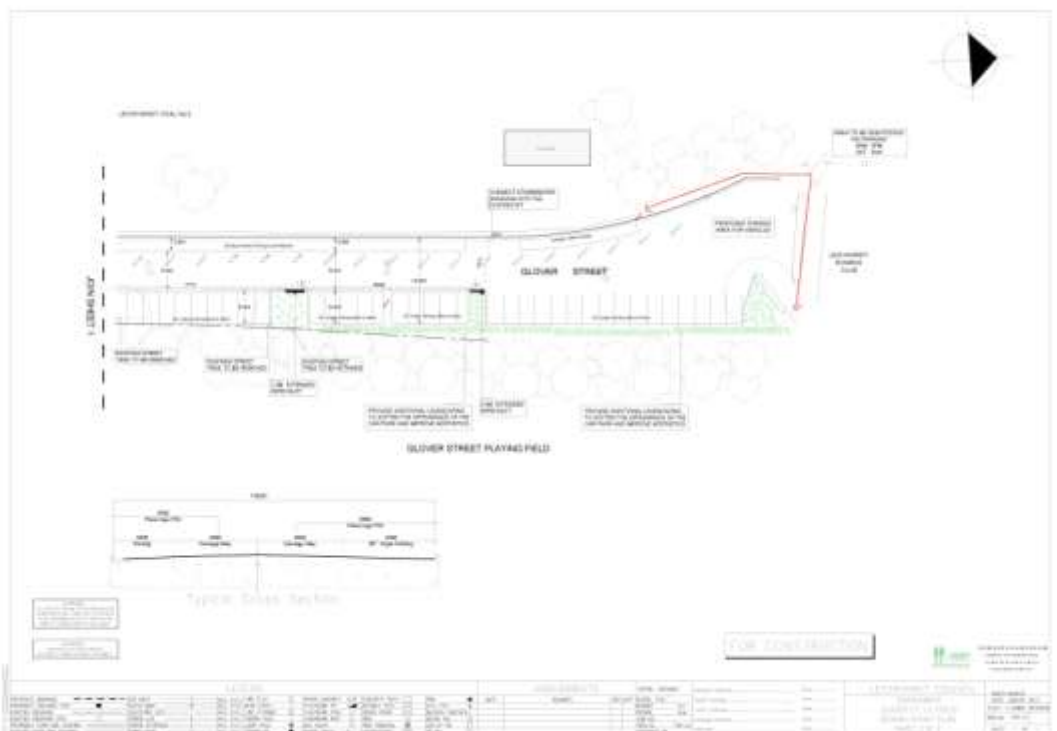

CLUB CHAT

FLEET MAINTENANCE

A walk around the shed looking at the state of our boats and oars and the piles of equipment lying about the floor suggests a cultural change of heart is required at LRC. I need all members to help me address this issue.

Replacing old equipment is an instant focus of your new Committee, but we must maintain what we have until it can be replaced or we will all struggle to get on the water this season.

The corporate event will have finished on Sunday 9 September, then we start Learn to Row. Both these activities are tortuous on our equipment and I know it is frustrating for you all to watch the damage occurring right in front of you. However, these events are a source of the very funds we need to replace and restore our equipment. All members simply need to ensure we minimise damage where ever we can. I also recognise that storage around the shed needs rationalisation and better arrangement. We are working on that too, but in the meantime do your bit and clean up as you go. Don't leave any equipment just lying around. Find somewhere to store it safely.

That's where I need your help. If you see a job needing to be done or a break occur or an activity taking place that risks damage; step in, lend a hand and show people how to look after our fleet or get it repaired. Don't leave it to "someone else". From now on "someone else" has left the club and is no longer available to take care of what you turn your back on.

Washing boats down also needs to be improved. When you do this task remember that it's the metal fittings and moving parts that need most of the attention. Whilst the hulls need the salt water washed off; that's the easy part which should take the least time. Washing down riggers and slides needs far more attention and care to remove salt residue. I'd like to see more attention to this after each row please.

In the coming weeks we will soon schedule a maintenance day to review the condition of selected boats, but until then please exercise a little ownership of our equipment by feeling free to make any repairs needed if you have the skills. If not approach Charles Bezzina for some assistance, I know he is keen to make a difference.

HEAD OF THE YARRA

For those going to Melbourne for the Head of the Yarra, we have made a block booking at the Travel Lodge. The Travel Lodge is located a short walk from the boatsheds at South Gate. If you wish to make a booking you can contact them on:

T: + 61 (0) 3 8696 9600

F: + 61 (0) 3 9690 1160

Address: 9 Riverside Quay, Southbank, VIC, 3006 or

BOOK ONLINE at www.travelodge.com.au **or call Travelodge Reservations:** 1300 886 886

When booking quote:

Group Name – Leichhardt Rowing Club 2012

Confirmation # 11107330

Rooms are available as follows on a first come first served basis

22nd Nov 2012 – Thursday - 10 x Standard Queen Rooms

23rd Nov 2012 – Friday - 25 x Standard Queen Rooms

24th Nov 2012 – Saturday - 25 x Standard Queen Rooms

Room only per night @ \$160.00

Room + Buffet Breakfast for 1 guest per night @ \$175.00

Room + Buffet Breakfast for 2 guests per night @ \$190.00

A Reminder that ENTRIES for HEAD OF THE YARRA must be with the Regatta Secretary by Sunday, 21 October. All rowers must be members of LRC and Rowing NSW. If any of your crew haven't rowed Head of the Yarra before or any national (rather than NSW) regattas, please let the Regatta Secretary know asap as they will need to be registered in the national ROMS entry system.

Let's hope the weather is kinder to us this year than last year!



REGATTA ROUND-UP

A Tale of Two Rivers: Scullers Heads of the Yarra and the Nepean

A group of six masters rowers braved the temperamental Melbourne weather, multiple bridges and tricky currents to row 8.5km in the Scullers Head of the Yarra in Melbourne. In a field of 115 scullers of all ages, Tim Tindale came a very respectable 34th in 33.12.3, closely followed by Brian Davis in 33.23.1 and David Hogan in 33.27.9. Brian scored the third best prognostic of all the rowers at 94.64% - just shaving out World Champion and Olympic Gold Medallist, sculling legend Peter Antonie at 93.83%. Dean Patterson, Anna Foley and Juliet Bourke all completed the course with solid times, despite sleet storms at the halfway mark, strong currents and a gusty headwind.



The following weekend, a group of juniors, open lightweights and masters rowers competed the Scullers Head of the Nepean.

Brigitte Hadley won the Open Lightweight category and was the fastest woman on the water, completing the 5km course in 10th overall at 23.23.91. Dimitri Kastanias also had a good race for his first scullers time trial, coming 12th overall with 24.00.78, closely followed by Rosa Brown in 14th with 24.15.61. Our juniors Dominic McEwen, Celso Milne and Jack Message all competed well, with a special mention to one of our newest juniors Sofia Milne. In the masters category, Brian Davis stormed home in a handicapped time of 23.49.69—27 seconds faster than the second placed rower, and also won the G age category. David Hogan was fastest of the E category men, Anna Hickey-Moody was the fastest A category woman, Daniela Borgert was the fastest B category woman and Anne Parbury was the fastest masters woman overall with a handicapped time of 25.32.85, and also won the F category MW1x.

(photos courtesy of Justin Milne—who also drove the trailer—thank you!)



REGATTA ROUND-UP

Program of Regattas and Club Events 2012

		Regattas	LRC and other dates
Sa	8-Sep	Head of the Nepean	
Su	9-Sep		LRC Corporate Challenge Regatta, SIRC
Sa	15-Sep		LTR Registration
Fr	21-Sep		End of Term 3
Su	22-Sep		LTR off-water session
Su	23-Sep		LTR 1
Mo - Fr	24-28 Sep		School Holiday Camp - TBC
Sa	29-Sep	NSWIS TT1, Nepean River	
Mo - Fr	1-5 Oct		School Holiday Camp - TBC
Sa	6-Oct		LTR 2
Su	7-Oct		LTR 3
Mo	8-Oct		Term 4 Starts
Sa	13-Oct	Shoalhaven Sprints	
Sa	13-Oct	Head of the Shoalhaven	
Su	14-Oct		LTR 4
Sa	20-Oct	RNSW Spring, SIRC	
Su	21-Oct		LTR 5
Sa	27-Oct	NSWIS TT 2, Nepean River	LTR 6
Sa	3-Nov	Iron Cove Classic, Iron Cove	
Su	4-Nov		
Sa	10-Nov	Head of the Parramatta	
Sa	17-Nov	St George RC, SIRC	
Sa	24-Nov	NSWISTT 3, Nepean River	
Sa	24-Nov	Nepean RC, SIRC	
Sa	24-Nov	Head of the Yarra	
Sa	1-Dec	Gold Cup, Lane Cove River	
Su	2-Dec		LRC Christmas party TBC
Sa	8-Dec	RNSW, SIRC	
Su	9-Dec	RNSW Sprint Championships, SIRC	
Fr	19-Dec		End of Term 4
Sa	22-Dec	NSWIS TT 4, Nepean River	20 Dec—1 January active rest

All regatta entry queries can be directed to Bec Storen at lrc.regattas@gmail.com Please note that regatta entries must be lodged with Bec no later than 5:00pm on the Sunday prior to the advertised closing date for entries. Late or incomplete requests will be refused and not lodged.

TECHNICAL TALK—RIGGING

Our new Property Master, Charles Bezzina, will be running a series of articles in *Easy Oar* covering the basics of rigging, derigging and transporting boats. The first of these articles, which originally ran in *Easy Oar* in 2009, covers what washers to use and in what order.

Washers and how to stack them

When we pull our boats apart, this is how all the parts (nuts, bolts and washers) fit together again.

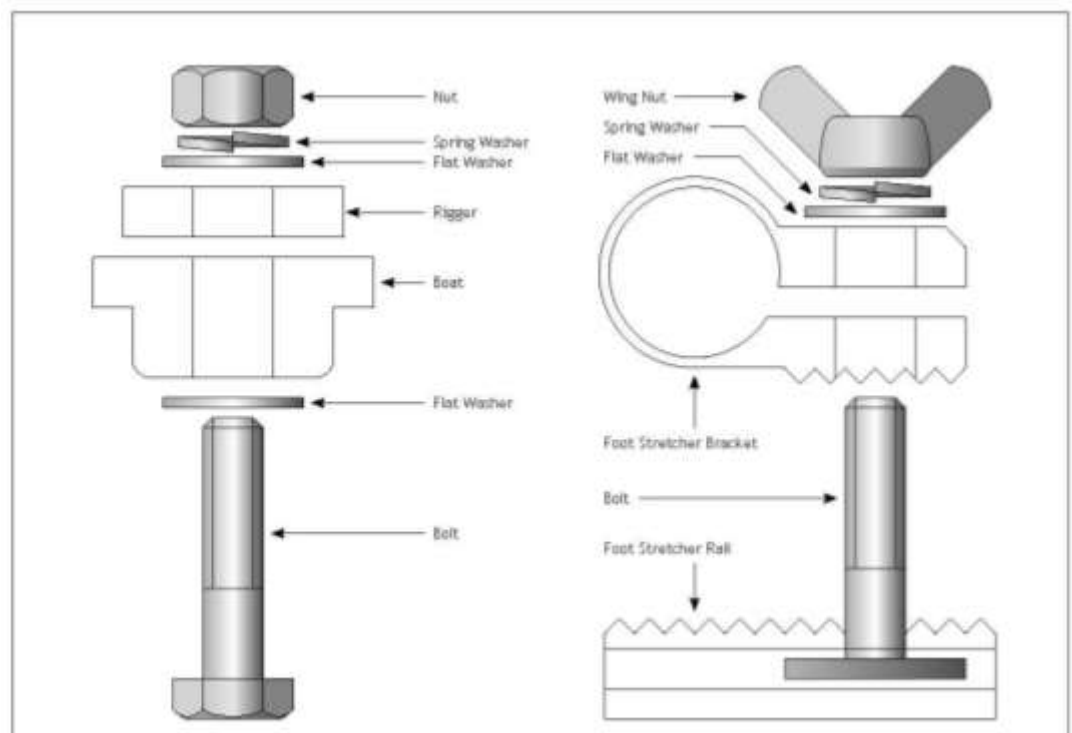

How to stack washers

Nuts, bolts and washers

When we assemble riggers (or any other part of a boat such as the foot stretcher) using nuts and bolts, it is important to use the correct washers, and to place them in the correct position. Tightening nuts without washers will damage the boat and its parts, and using the wrong washers will do even more damage, faster.

There are two types of washers (look in the regatta box). The flat washer is, unsurprisingly, shaped like a flat disc and the spring washer is shaped like a tiny spring—there is a gap, or break, in the disc with slightly curved edges. These washers serve different purposes and cannot be used interchangeably.

Flat washers

The flat washer protects both the boat and the rigger from the wear brought about by tightening and loosening the nut. It's easy to identify a rigger that has been tightened without a flat washer—the metal surface below the nut is worn. The flat washer also distributes the force of the nut and bolt over a larger area, reducing the possibility of crushing the boat or its parts.

Spring washers

The spring washer applies a spring force that prevents the nut from coming loose when rowing.

However, when a spring washer is compressed, the sharp edges bite into the surfaces that touch it, preventing them from turning. This is the rigger and boat killer. Every time a spring washer is tightened against an aluminium, fibreglass or plastic boat part and then loosened, it removes a significant amount of the boat material. It is easy to identify a rigger that has been tightened with a spring washer but without a flat washer, the metal surface below the nut is very badly worn.

Spring + flat = happy boat

Always use a flat washer when you use a spring washer, to protect the boat and its parts—it's essential.

Any washer, regardless of its type or outer size, should have a hole that fits neatly on the bolt. Both flat and spring washers should be the correct hole size for the bolt.

In summary:

- always use a flat washer on both ends of a nut and bolt when assembling parts of a boat
- always use spring washers, they prevent boats from coming apart while they are being rowed
- always use a flat washer to stop spring washers from touching any part of a boat, and
- washers must be the correct size for the bolt.